

# Design of Gratings for 3D Depth Sensing

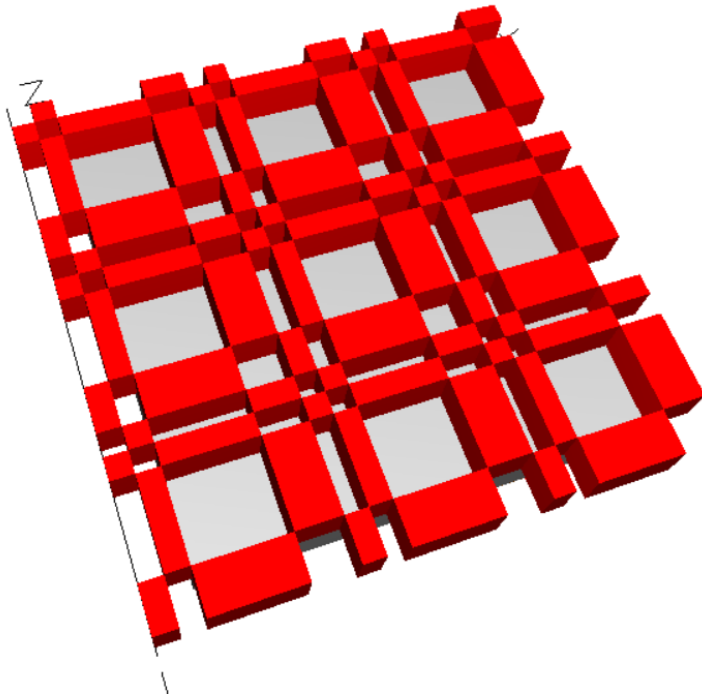

Tung Yu Su, Richard Hu, Morgan Lu  
Cybernet System Taiwan  
Acknowledgement: RSoft technical staff,  
SYNOPSYS

# Depth Sensing Overview

- Depth sensing has recently gained attention in a variety of applications
  - FACE ID in iPhone X, LiDAR...
- General principle
  - DS illuminates a sampling signals onto objects, and detects the reflected signals
  - Depth information can be deduced by analyzing the reflected signal with algorithms
- Several methods for analysis are studied:
  - Time of Flight(TOF), Stereoscopic Vision(SV), Structured Illumination(SI)....,etc.

|            | TOF     | SV  | SI     |
|------------|---------|-----|--------|
| Resolution | Low     | Low | High   |
| Distance   | 0.3m-8m | <3m | 0.3-1m |
| Cost       | High    | Low | Low    |

- In this presentation, structured illumination will be introduced, with improvements to cellular phone technology as the target application.

# Structured Illumination

- Structured illumination is widely used in microscopy for enhancing spatial resolution by illuminating the sample with patterned light and using software to analyze the information in Moiré fringes outside the normal range of observation
- Challenges:
  - Generation of regular structured light
  - Generation of random structured light
- Possible solutions and their drawbacks
  - **Regular structured light: Periodic 3D gratings** can be applied to generate a regular light pattern, but a “regular sampling pattern” stands for the pattern at any given location in the image is not locally unique.
  - **Random structured light: A customized phase plate** can be applied to generate almost any pattern with phase retrieval techniques, but the cost is relatively high and the tolerance might be very sensitive because of the lack of periodic properties.
- In this presentation, periodic 3D gratings will be introduced.
  - Pattern uniformity can be improved by using a source array with dynamic control of the stripe period

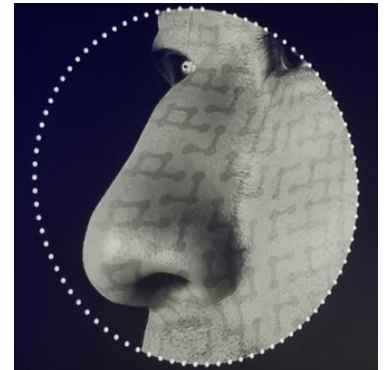

# Optical Gratings

- In order to generate a structured pattern, the requirements and expected conditions are:
  - Input source: An array of IR laser diodes(VCSEL, DFB) is candidate to perform a light source with good coherence and polarization
  - Output pattern: Widely separated patterns, uniformly distribution of intensity
- Based on the above requirements, a set of specifications is listed:

| Items              | Specifications                                |
|--------------------|---|
| Source             | VCSEL Array (850-890nm)                       |
| Working Distance   | 20cm-1m                                       |
| Field of View(FOV) | >90°  |
| Transmittance      | >70%  |
| Uniformity         | >70%  |
| Number of Orders   | At least -4 <sup>th</sup> to +4 <sup>th</sup> |

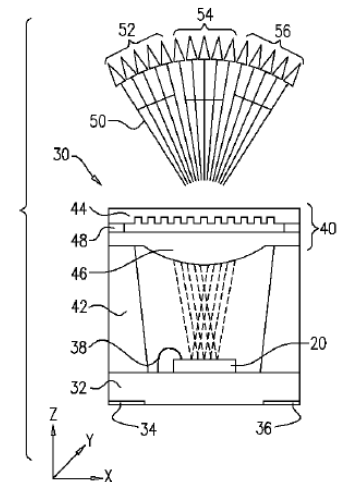

# Dammann Grating

- Many different approaches for constructing array generators have been reported, and one of the oldest and most successful is the binary diffraction grating proposed by Dammann et. al.

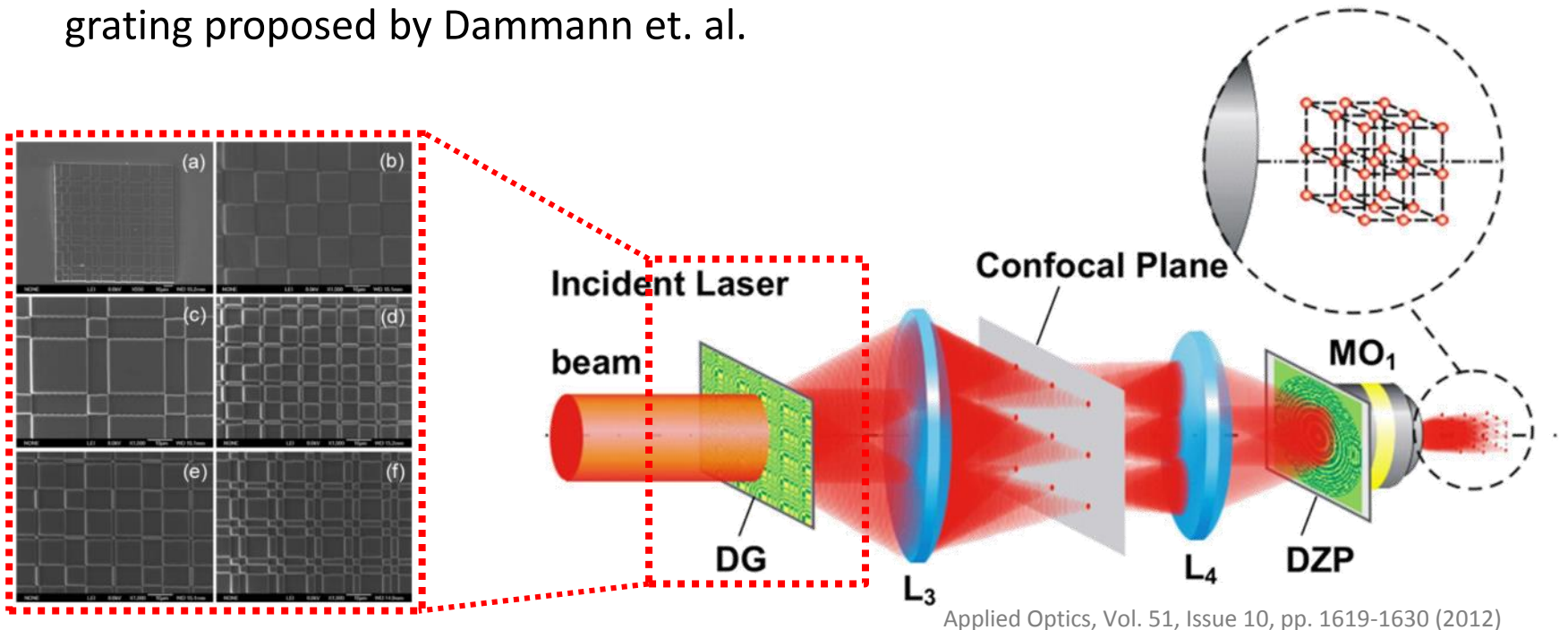

- Dammann Gratings (DG) can be manufactured by lithography-based processing platform
  - Tiny features can be designed with low cost

# Dammann Grating

- Dammann Grating is a two-dimensional pattern with a set of fractions in a single period:

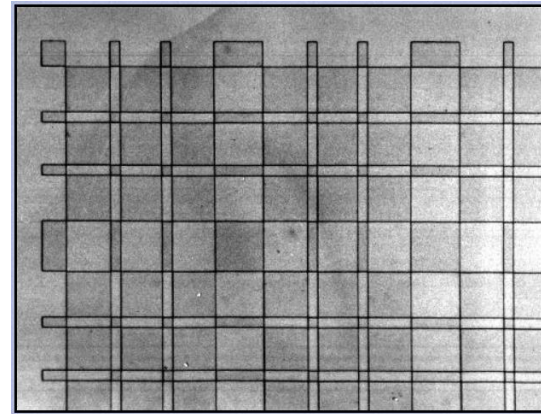
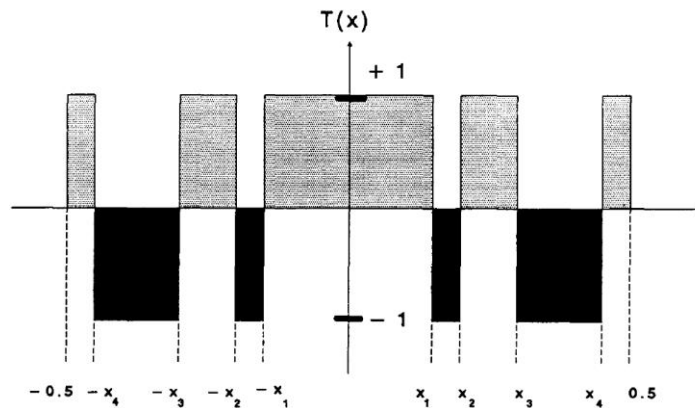

- To properly design Dammann grating, there are two approaches:
  - Numerically solve the theoretical equations by mean square deviation to optimize the parameters ( $x_1, x_2, -x_1, -x_2, \dots$ , etc)
  - Build a model by RSoft CAD layout tools, solve the properties by DiffractMOD (RCWA-based simulation tool).
- In this presentation, a DG model will be built in RSoft CAD and DiffractMOD will be used to simulate the diffraction properties.

# RSoft CAD Layout

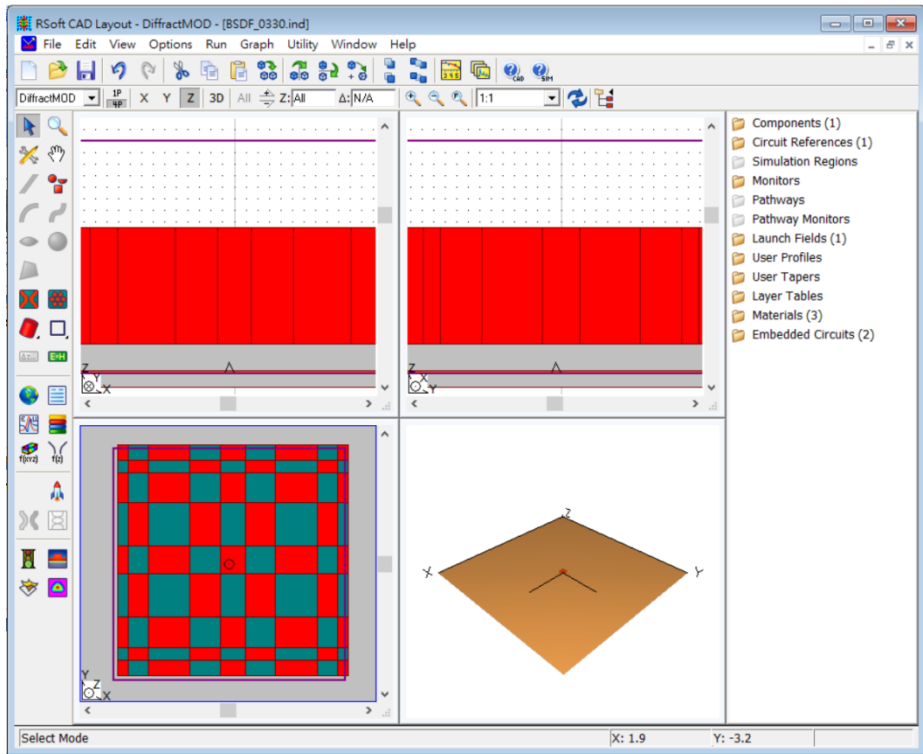

- RSoft CAD is a powerful layout tool with user-friendly GUI. Models built in RSoft CAD can be simulated by all RSoft's passive tools
- All features are able to be parametrically defined, providing a full space for optimization
- Users are able to export and import mask layout files directly

# DG Model in RSoft CAD Layout

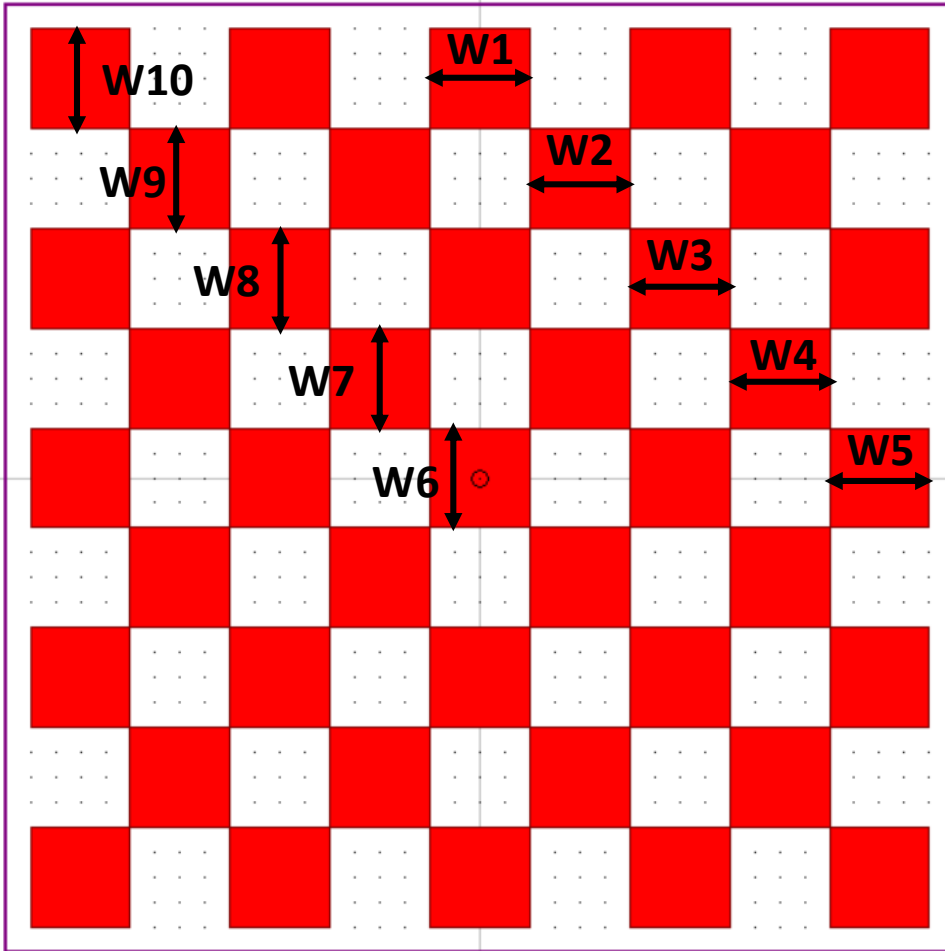

- In this case, a checkerboard-like grating is defined with 10 variables which control the width of each “block”
- The red blocks stand for a material with a specific (and variable) index
- Every quadrant of the grating has the same design, so that this grating emits light symmetrically



# DG Model in RSoft CAD Layout

- The variables in this DG model are :
  - Period
  - Width of every block
  - Height of every block, which is a single value to make sure only one mask will be involved
  - Refractive index of every block and the substrate

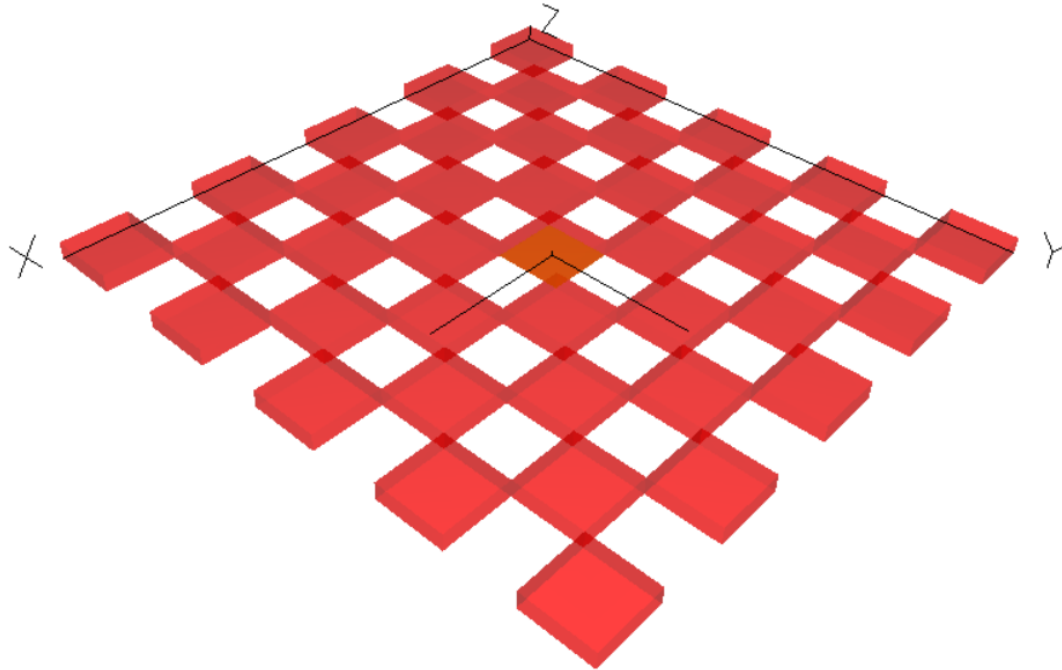

# Choose an Algorithm

- To rigorously simulate diffraction properties, RSoft's DiffractMOD is chosen:
  - DiffractMOD is an efficient tool to calculate the reflection and transmission of transversely periodic devices
  - Based on Rigorous Coupled Wave Analysis (RCWA)
  - RCWA solves the Helmholtz equation
    - Transversely periodic structures
    - Monochromatic
  - Typical applications include:
    - Diffractive optical elements
    - Lithography phase mask
    - Solar cells
    - AR/HR coatings

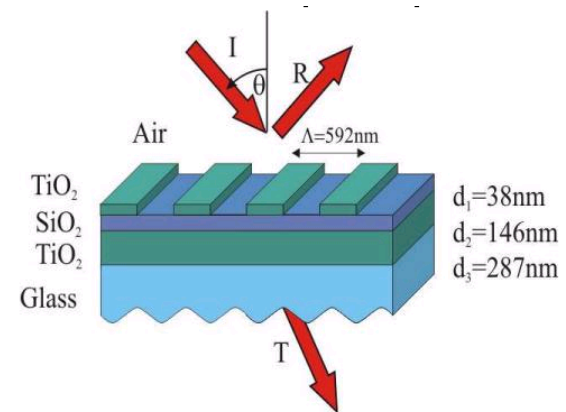
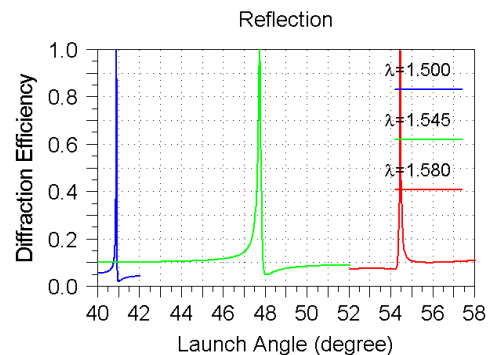
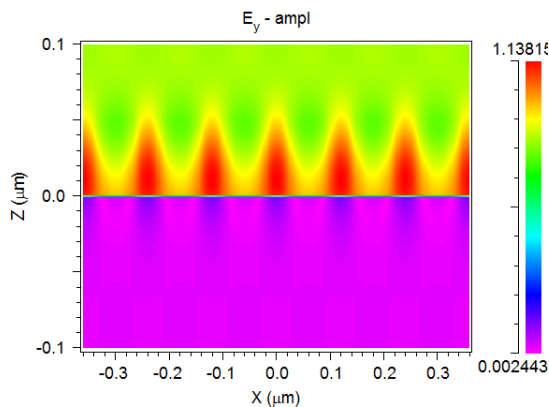
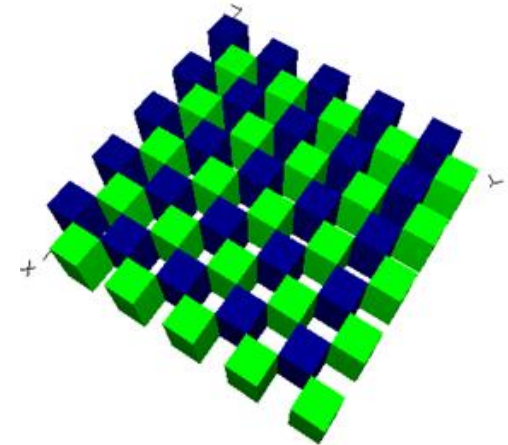

# DiffractMOD Output

- Outputs from DiffractMOD
  - Reflection/Transmission power for each diffraction order
  - Total reflection/transmission
  - Amplitude/Phase/Angle for each diffraction order
  - Field distribution in simulation domain

Output Options

Plot Selection  
Plot Type: Single Value

Min: 0.4  
Max: 0.6  
Step: 0.01

Figure of Merit

|   | X    | Y   | Z |
|---|------|-----|---|
| <input type="checkbox"/> Reflection:                        | -2.2 | 0   | 0 |
| <input checked="" type="checkbox"/> Transmission:           | 0.5  | 0.5 | 0 |
| <input checked="" type="checkbox"/> Total Reflected Power   |      |     |   |
| <input checked="" type="checkbox"/> Total Transmitted Power |      |     |   |
| <input type="checkbox"/> Absorbed Power                     |      |     |   |

More ... Advanced ...

Calculate Field

Output Location  
 Reflection Plane  
 Transmission Plane  
 On Grid (combined)  
Options ...

Field Component  
 Default Field  
 Ex  Ey  Ez  
 Hx  Hy  Hz

Format  
Amplitude

Open Results

Output Grid

|       | X       | Y       | Z       |
|-------|---------|---------|---------|
| Min:  | default | default | default |
| Max:  | default | default | default |
| Step: | default | default | default |

Help Symbols ... OK Cancel

# Convergence study in DiffractMOD

- To examine the accuracy of simulation, a convergence study is needed
  - Make sure the number of harmonics is sufficient to this case
  - Convergence study is a case-dependent property, and thus it should be done after optimization

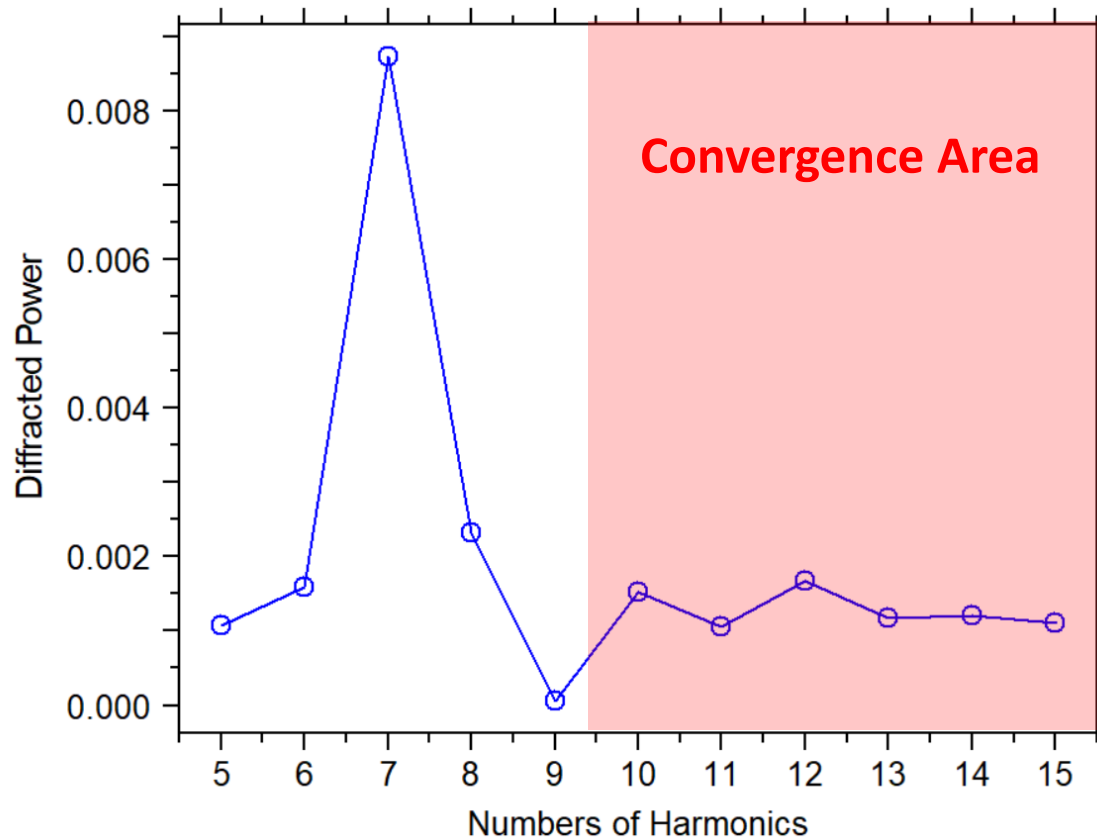

# DiffractMOD Simulation

- The diffracted angle should be the first specification to be defined
  - The Period is the key parameter
- The MOST SCAN tool is used to automatically scan the change of period and plot the relationship between diffraction angle and period

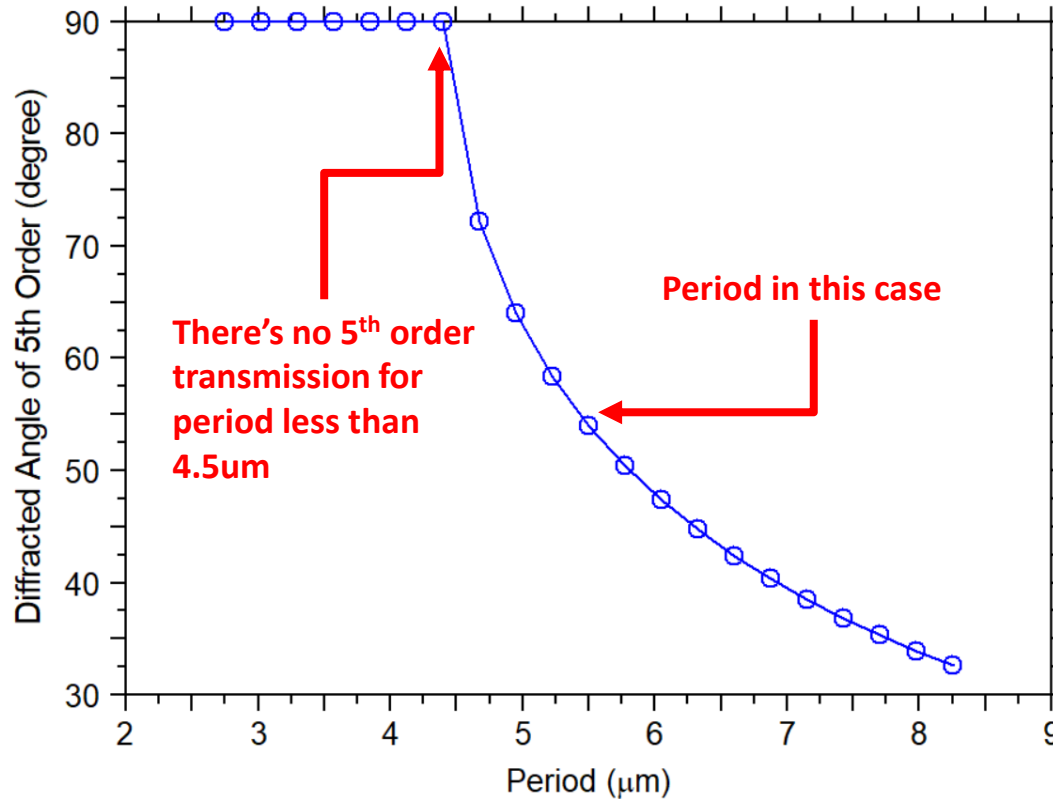

# DiffractMOD Simulation

- Fix "Period" to 5.5um and run simulation to check the output angle plot:

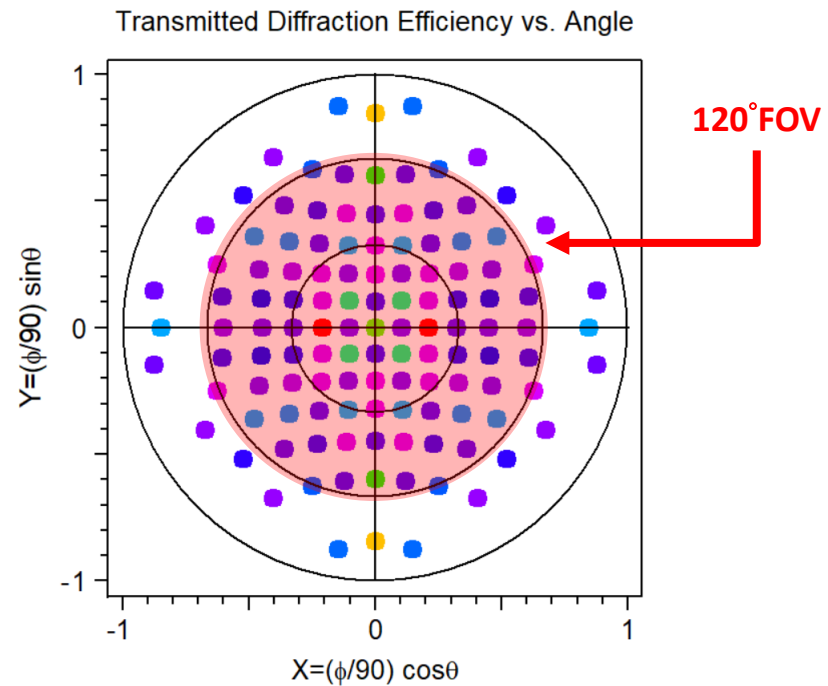
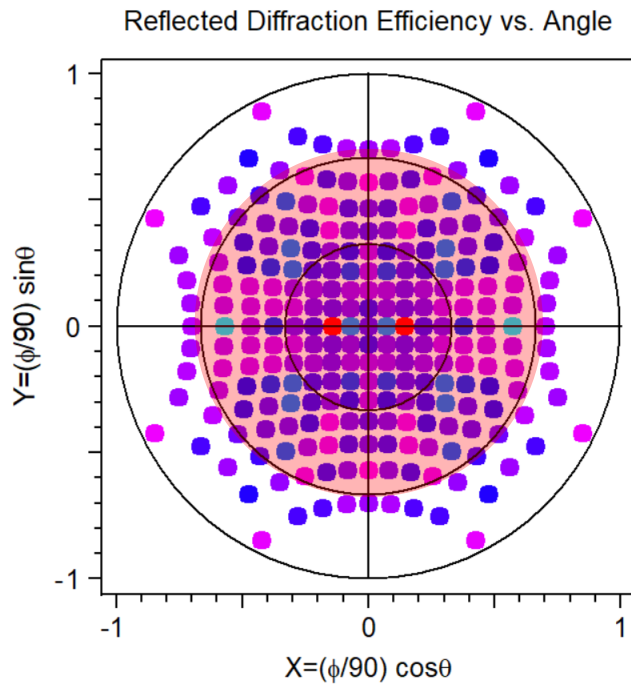

- Transmitted power from -5<sup>th</sup> to 5<sup>th</sup> order covers FOV about 120°

# DiffractMOD Simulation

- Check the uniformity of the transmitted power distribution

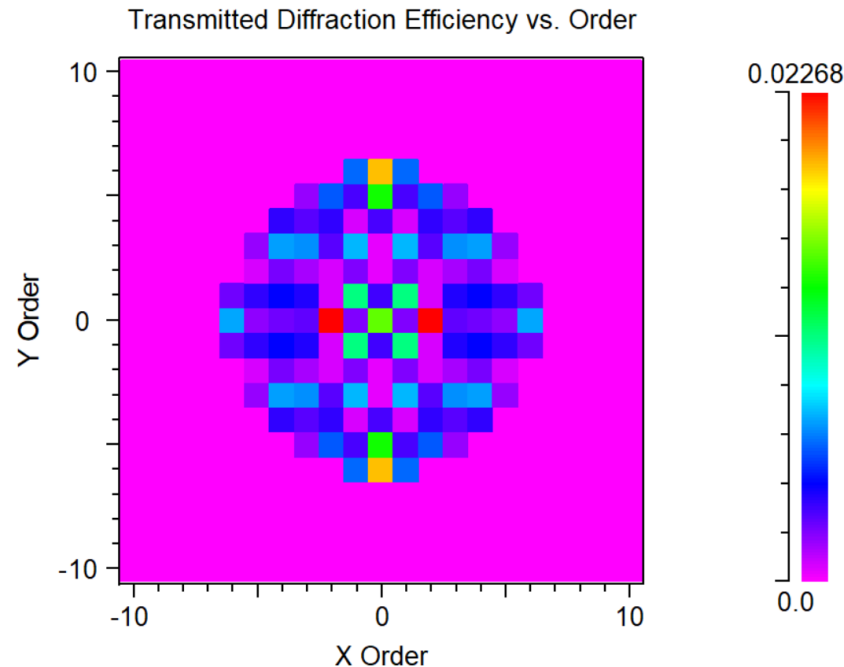

- For this structure, the transmitted power demonstrates “empty orders” and a nonuniform separation. In addition, certain angles contain less power
- An optimization of the DG is needed

# Design Challenges

- This model is a prototype, and the variables are randomly set in order to examine the outputs
- So far, some challenges of design are found by DiffractMOD
  - Transmitted power didn't distribute uniformly
  - The transmitted power of some certain orders are almost zero
  - Total transmitted power is too low (<60%)
- In order to match the required specifications, a multi-variable optimization must be performed. There are too many variables in the problem for scanning alone to be tractable.
  - MOST (Multi-variable Optimization and Scan Tool) is a powerful design tool to optimize photonic devices
  - Simulation algorithm can be any RSoft device tool or user-defined
  - Output can be built-in or user-defined
  - Error function can be defined easily via formula or Python code



# MOST Optimization

- Before performing a successful optimization, a suitable error function should be clearly defined
- In this case, the diffraction angle should not be changed so “Period” is not the optimization variable
- The target of this optimization is the “uniformity” of transmitted power; there shouldn’t be transmitted orders with  $\sim 0$  power
- A user-defined error function should be defined in MOST optimizer

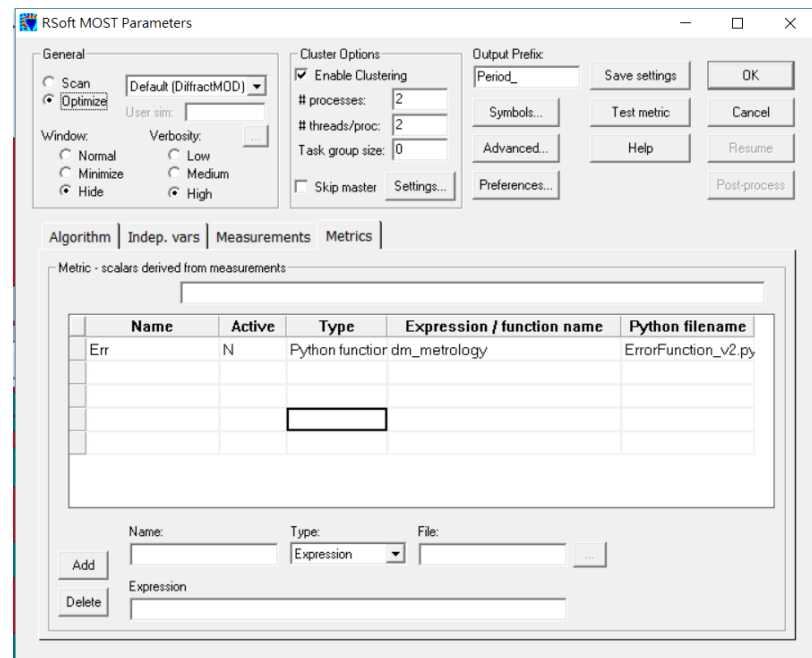

# Optimization by MOST

- To fully control the error function, a Python-code-based function is defined
  - Set the target power is 0.826% (assuming a unit power is equally divided into 121 orders)
  - Total error value is the summation of the power difference from every order
  - MOST Optimizer will run simulation based on genetic algorithm to minimize the total error

```
Target=0.00826
```

```
err0 =abs(T00_data-Target)+abs(T01_data-Target)+abs(T02_data-Target)+abs(T03_data-Target)+abs(T04_data-Target)+abs(T05_data-Target)
err1 =abs(T10_data-Target)+abs(T11_data-Target)+abs(T12_data-Target)+abs(T13_data-Target)+abs(T14_data-Target)+abs(T15_data-Target)
err2 =abs(T20_data-Target)+abs(T21_data-Target)+abs(T22_data-Target)+abs(T23_data-Target)+abs(T24_data-Target)+abs(T25_data-Target)
err3 =abs(T30_data-Target)+abs(T31_data-Target)+abs(T32_data-Target)+abs(T33_data-Target)+abs(T34_data-Target)+abs(T35_data-Target)
err4 =abs(T40_data-Target)+abs(T41_data-Target)+abs(T42_data-Target)+abs(T43_data-Target)+abs(T44_data-Target)+abs(T45_data-Target)
err5 =abs(T50_data-Target)+abs(T51_data-Target)+abs(T52_data-Target)+abs(T53_data-Target)+abs(T54_data-Target)+abs(T55_data-Target)
```

```
err=err0+err1+err2+err3+err4+err5
```

```
if extras['verbosity']: print "Python metric found %g \n" % err
```

```
return err
```

# Optimization by MOST

- MOST optimizes 9 design parameters with Genetic Algorithm
- Close to one million simulations run
  - Optimization was calculated on a 4 cores (Intel i7) computer
  - Optimization stopped due to the auto-convergence setting, taking approx. ~60hrs

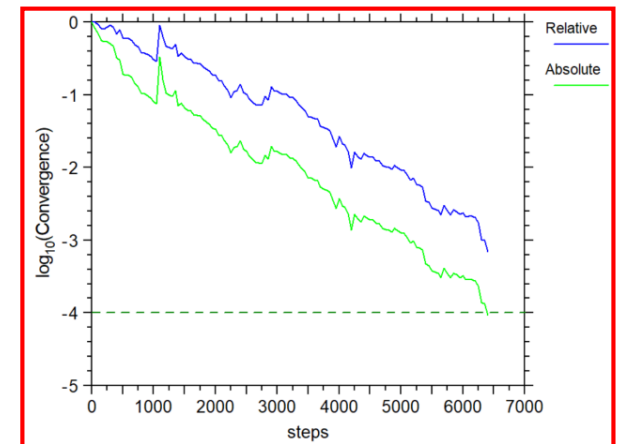
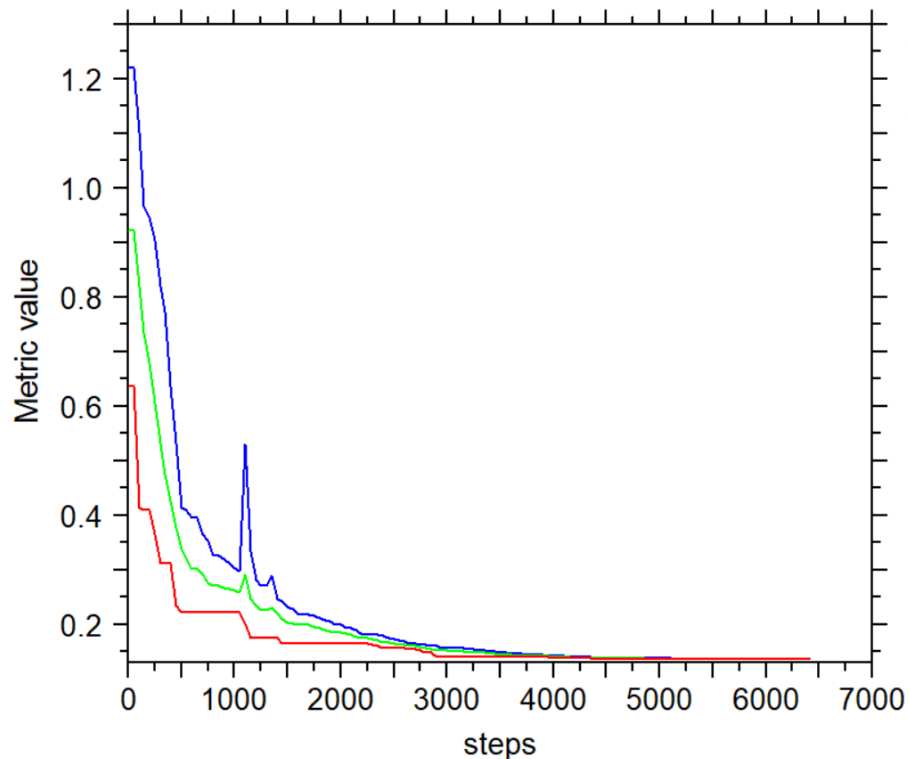

# Optimized Design

- DG is optimized in this optimization
  - A single period of structure was simulated and optimized, but users can easily replicate a single period into the whole structure for the purpose of mask generation.

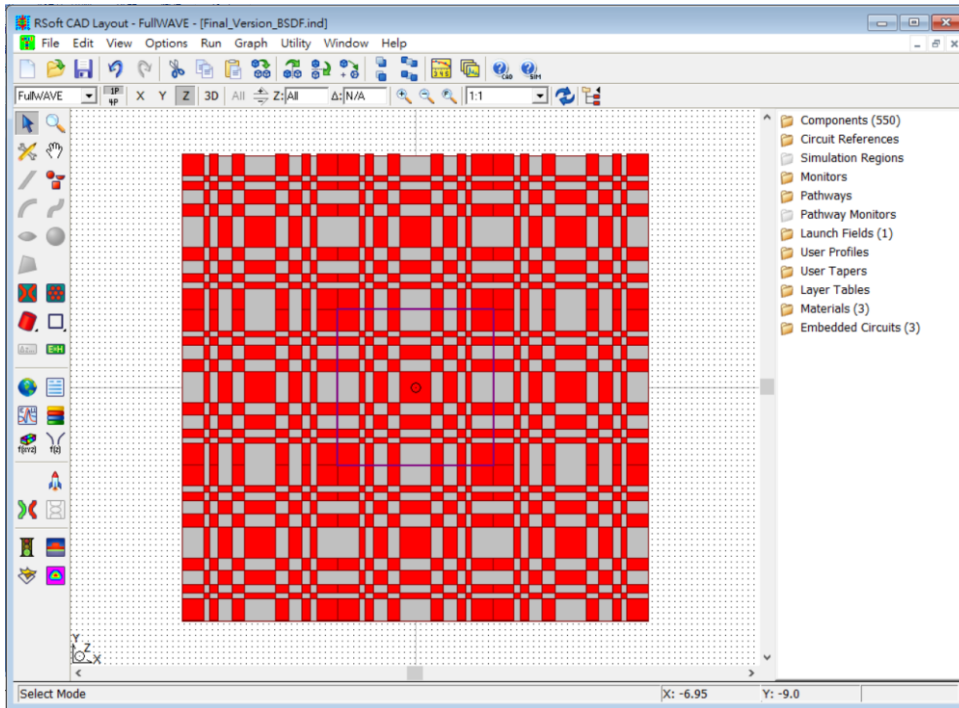
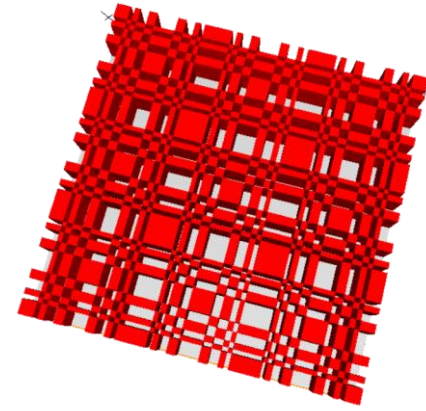

**Optimized Layout in RSoft CAD**

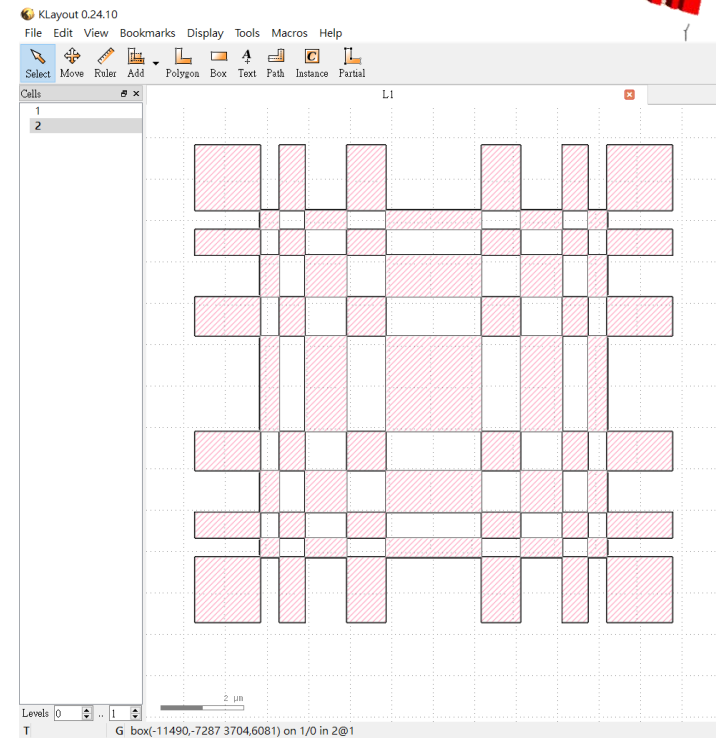

**GDS-II Layout in KLayout**

# Optimized Design

- Transmitted power distributed within  $120^\circ$  FOV
- Nonzero transmitted power appears in all orders

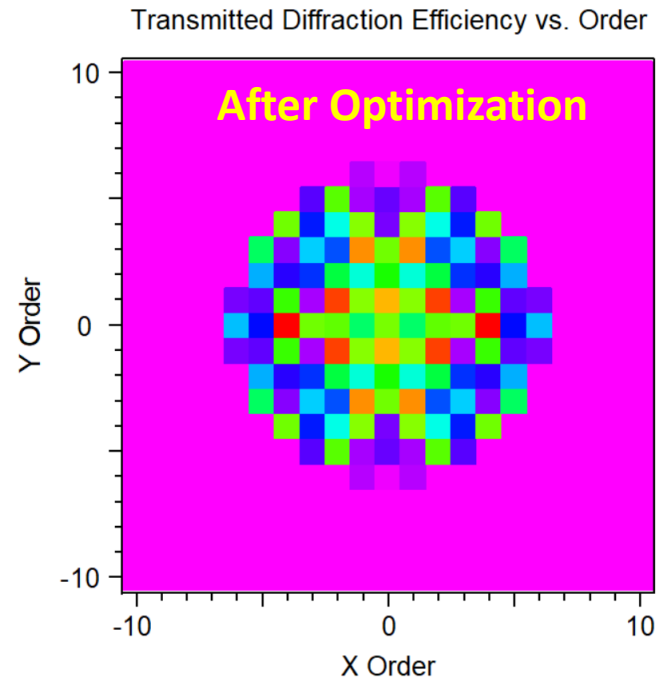
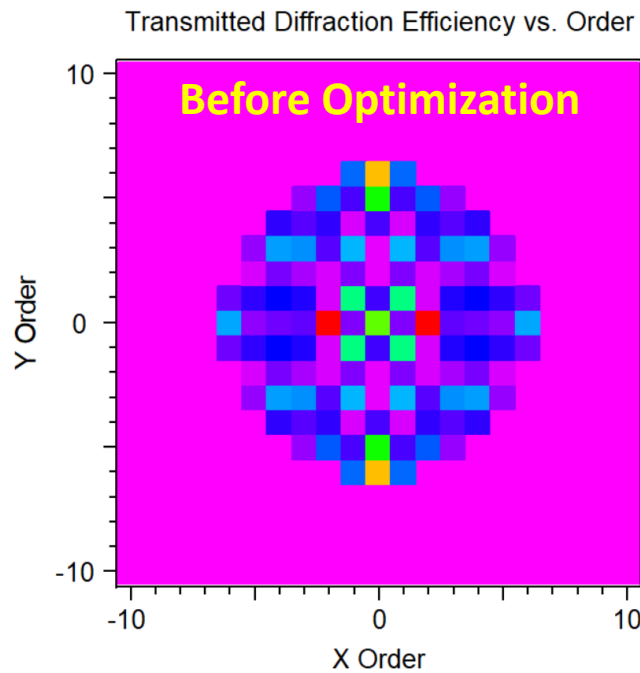
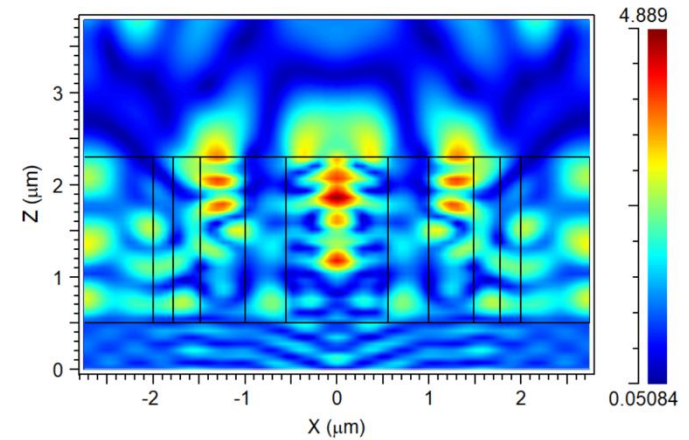

# Tolerance Analysis

- To fully investigate the grating performance, parameter sensitivities should be simulated in RSoft CAD & DiffractMOD
  - Variables can be properly defined as random values
  - The distribution of randomness should be provided by manufacturers
- In this case, a **5%** deviation of the parameter values was added into the simulation, and 200 simulation trials performed; the tolerance was analyzed via the Monte-Carlo method

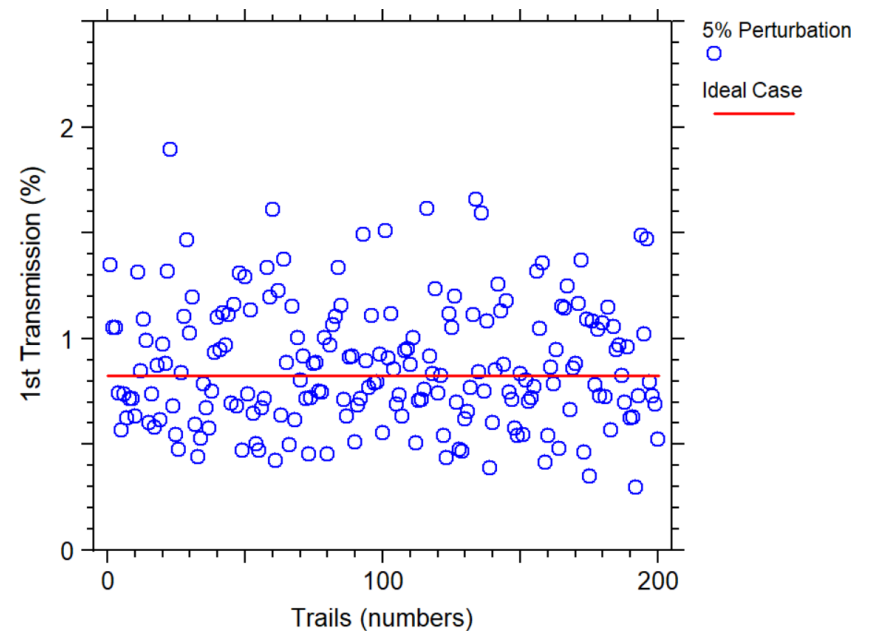
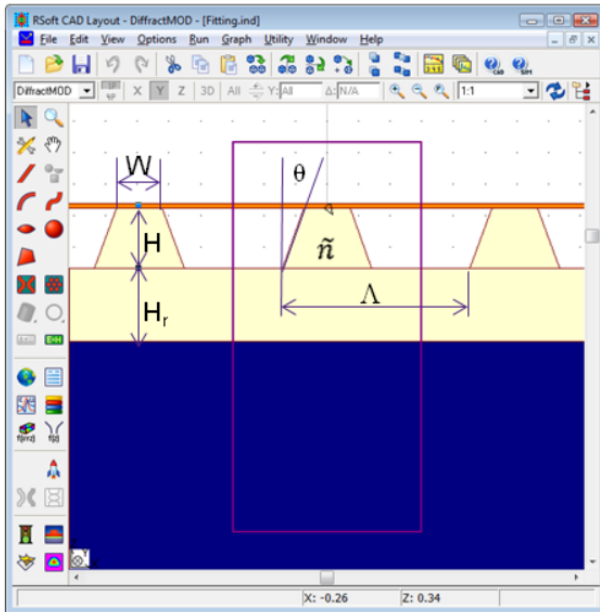

# Going from RSoft to LightTools

- While RSoft provides a detailed model of the grating, it cannot simulate the detailed effects of the illumination and/or lens systems
- RSoft and LightTools co-simulation provides designers with a highly accurate method for modeling surface scattering properties and helps achieve stringent size, weight, efficiency, and cost targets:
  - Calculate an RSoft BSDF (Bi-Directional Scattering Distribution Function) file using DiffractMOD or FullWAVE
  - Define a surface property in LightTools using the RSoft BSDF file via the RSoft UDOP

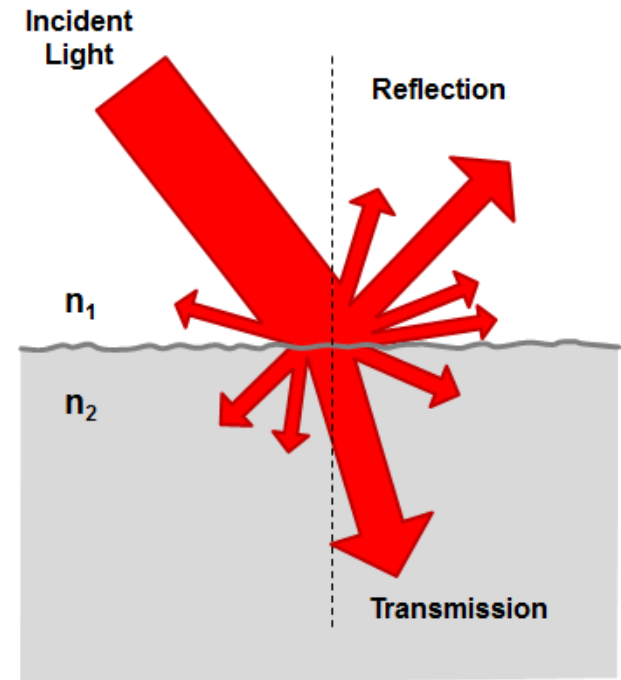

# RSoft BSDF Calculation

- Angular range of RSoft BSDF file:
  - Phi (from normal): Range of [0,5] since incident light has a limited range with  $0.1^\circ$  spacing
  - Theta (around normal): Range of [0,360] since the structure is anisotropic with  $15^\circ$  spacing
- BSDF Utility automates the DiffractMOD simulations; both polarizations are automatically calculated

BSDF Generation Utility

| Scan Parameters | Min  | Max  | Step Size |
|-----------------|------|------|-----------|
| Wavelength:     | 0.89 | 0.89 | 0         |
| Phi:            | 0    | 5    | 0.1       |
| Theta:          | 0    | 90   | 15        |

Sim Windows:  
 Normal  
 Minimize  
 Hide

Cluster Options:  
# Processes: 1  
# Threads/Proc: 2  
 Auto Threads

Output Prefix: dftmp

Buttons: Help, Symbols ..., Advanced ..., Save Settings, OK, Cancel



# Integrating Gratings with optical system

- Through the BSDF interface, the grating's diffraction properties can be easily integrated into LightTools, along with projector system which is designed by CODEV

**Projector System  
with DG attached**

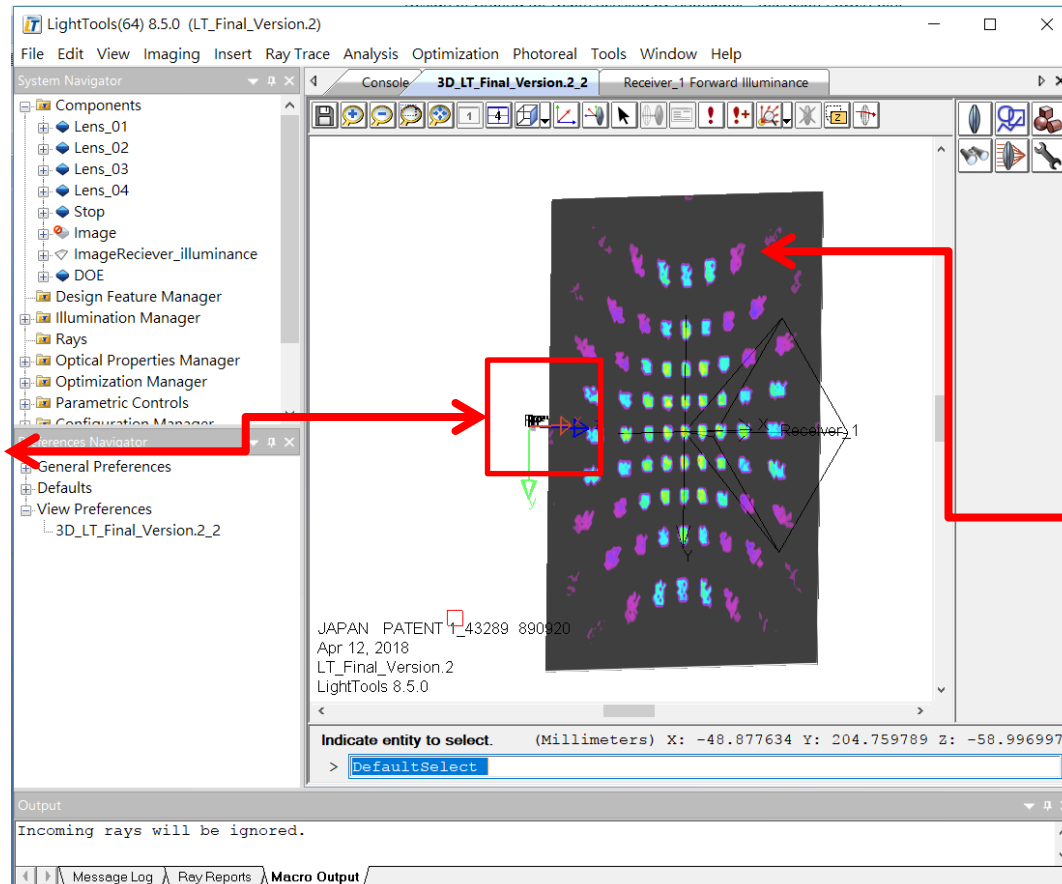

**Sampling area**

# Projector System

- Projector system can be designed and optimized in CODEV and exported to LightTools directly

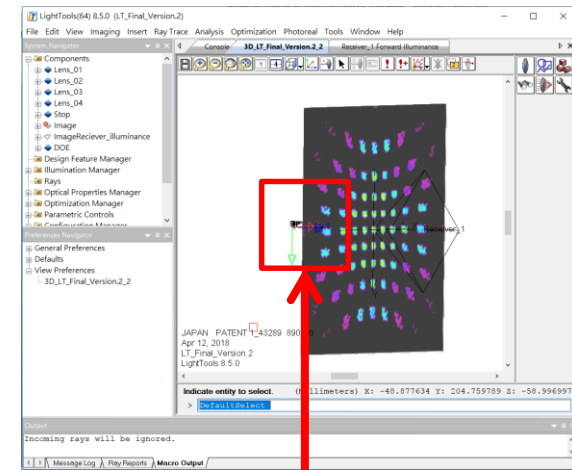

VCSEL array

Lens Setup

BSDF file (DG)

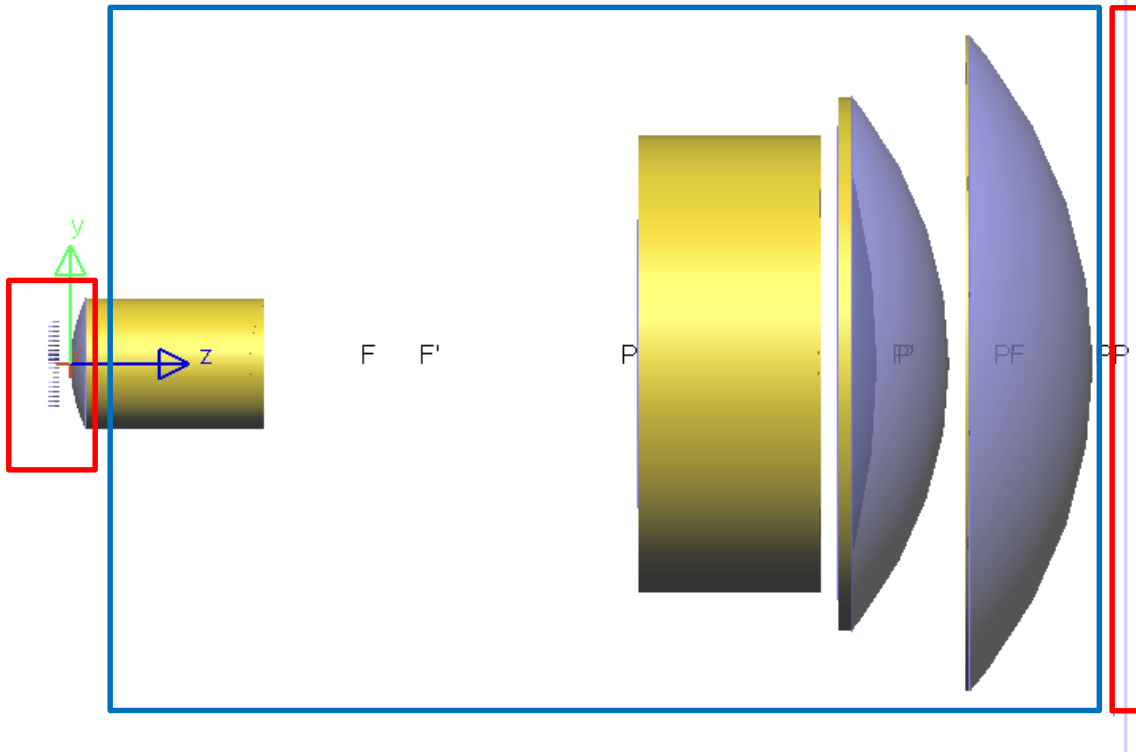

# Sampling Area

- Dots from a VCSEL array are split into an array, forming a larger pattern of dots
  - Diameter of imaged dots is about 0.5mm
- By randomly enabling the VCSELs in the source array, the output pattern can be pseudo-random

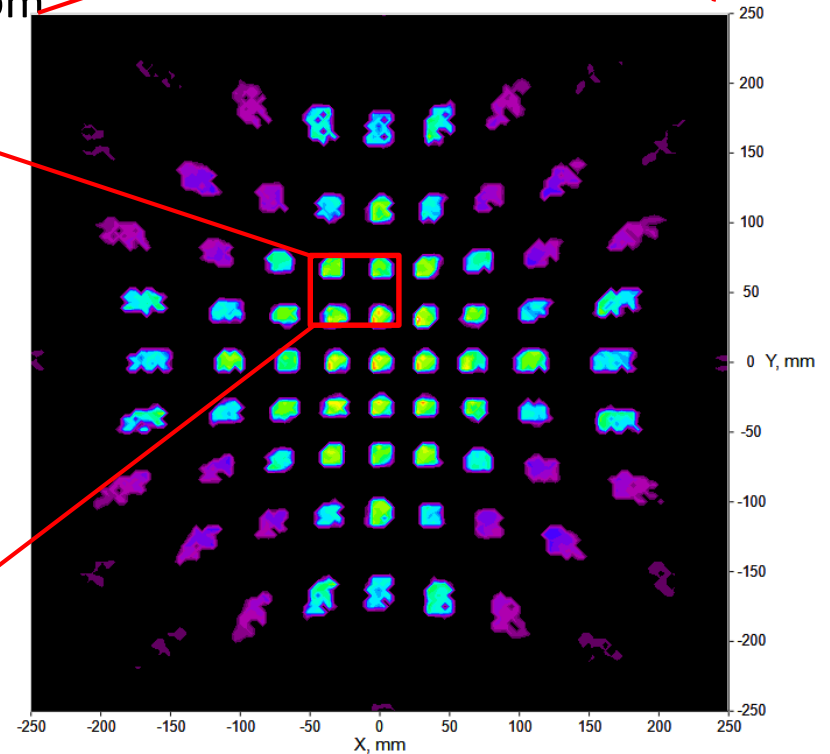
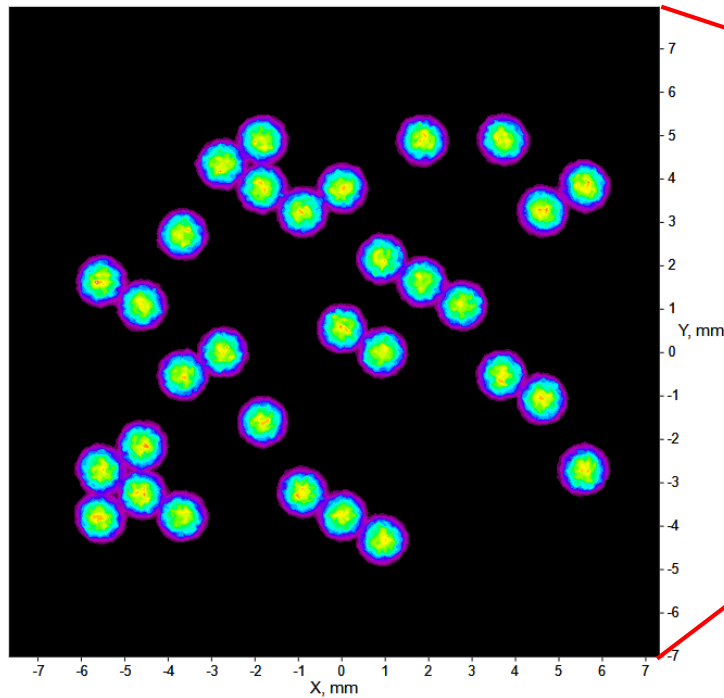
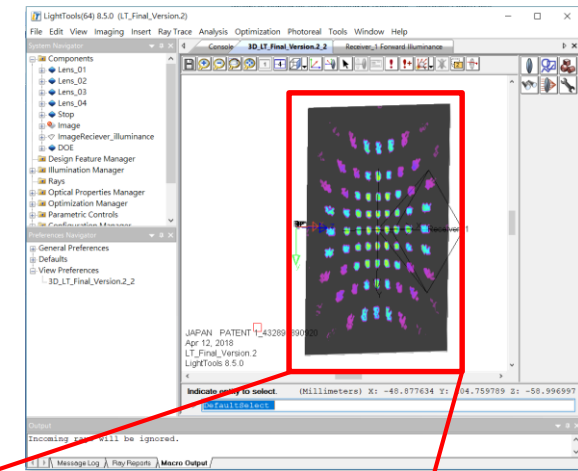

# Sampling Area

- In a suitable working distance (20cm), the sampling area covers around 40cm  $\times$  40cm, which is sufficient to the application of cell phone face-detection

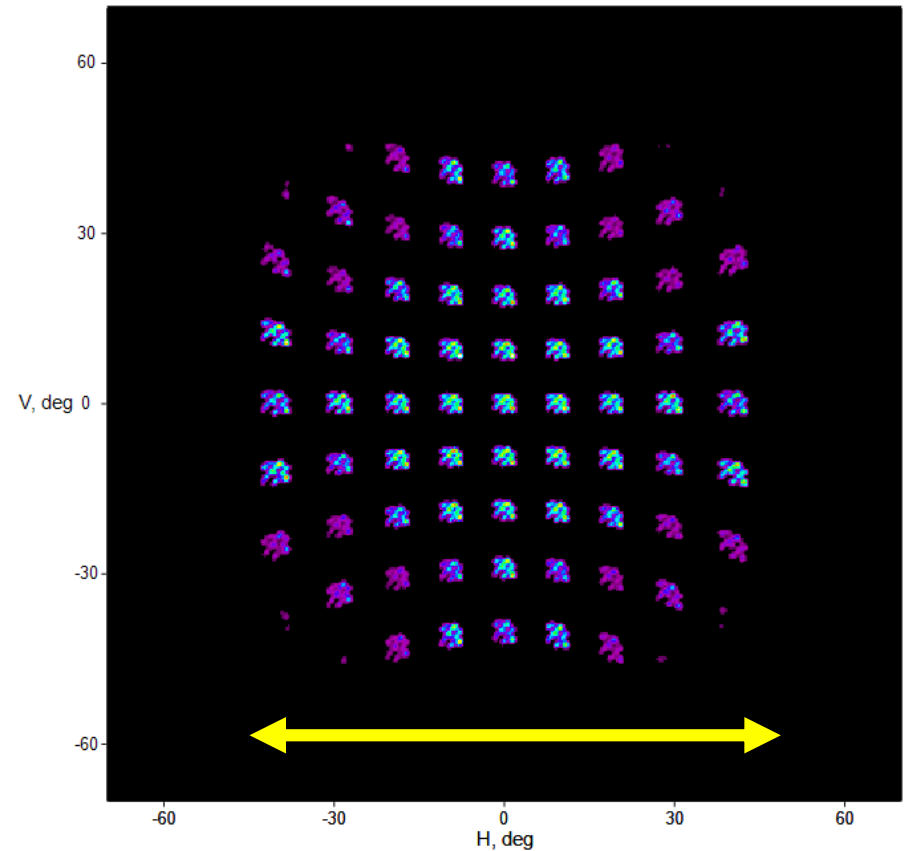
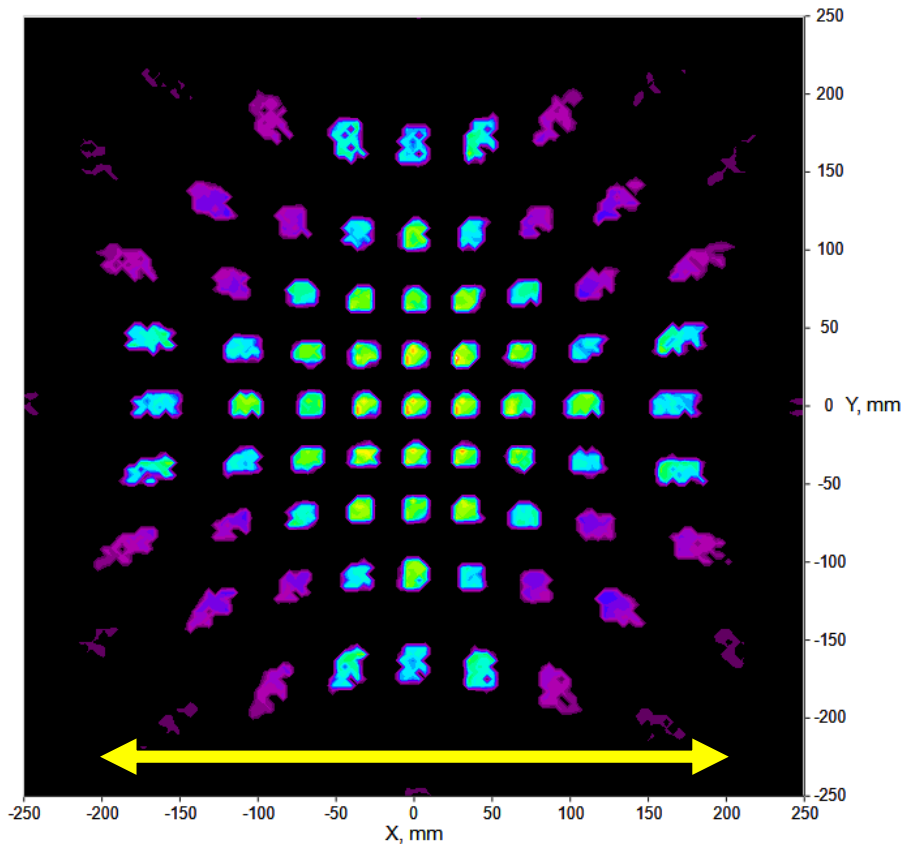

# Specification

| Items            | Specifications                                | Optimized Design   |
|------------------|---|--|
| Source           | VCSEL Array (850-890nm)                       | Checked  |
| Working Distance | 20cm-1m                                       | 20cm   |
| FOV              | $>90^\circ$                                   | $95^\circ$   |
| Transmittance    | $>70\%$                                       | 71%  |
| Uniformity       | $>70\%$                                       | <b>69%</b>   |
| Number of Orders | At least $-4^{\text{th}}$ to $+4^{\text{th}}$ | $-4^{\text{th}}$ to $+4^{\text{th}}$ (X)<br>$-5^{\text{th}}$ to $+5^{\text{th}}$ (Y) |

- Working distance can be tuned by a zoomed lens system
  - In this case, a system with 20cm working distance is demonstrated
- Uniformity can be improved with continued optimization of the gratings

# Optical System Optimization

- There are some spaces (marked in yellow) between the diffraction orders, which will cause the detection to fail there:

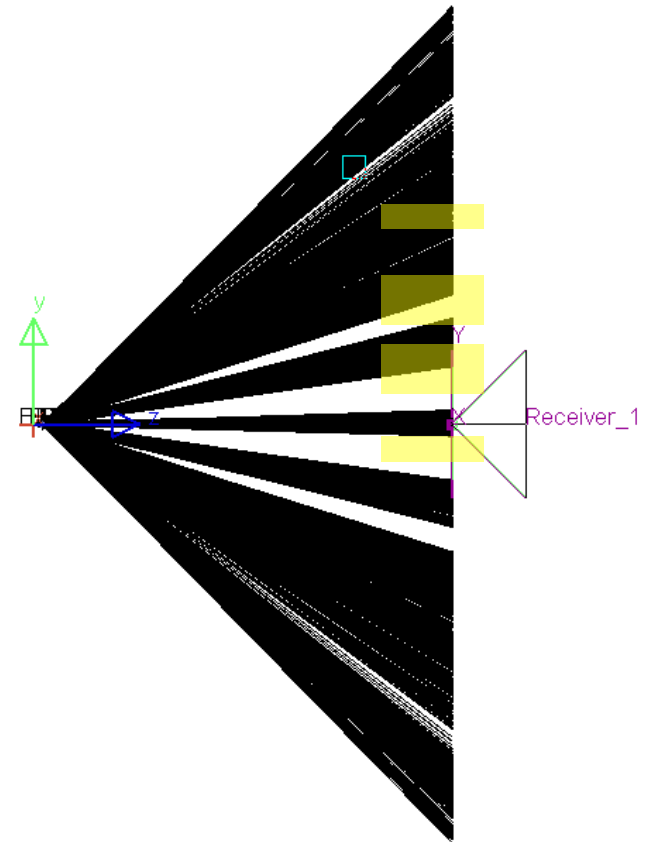
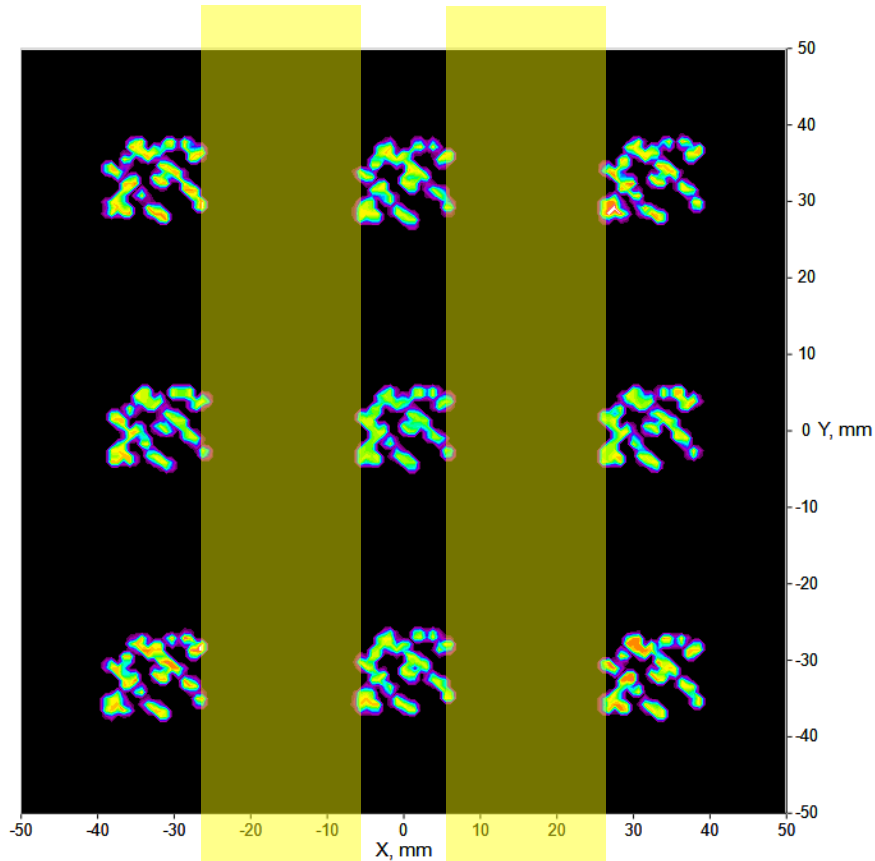

# Optimization of Optical System

- The lens/projector system is re-optimized after inclusion of the grating in CODEV and LightTools
  - A projector system with a larger aperture is optimized
  - Considering other constraints, such as mechanical limitations, stray light...,etc.

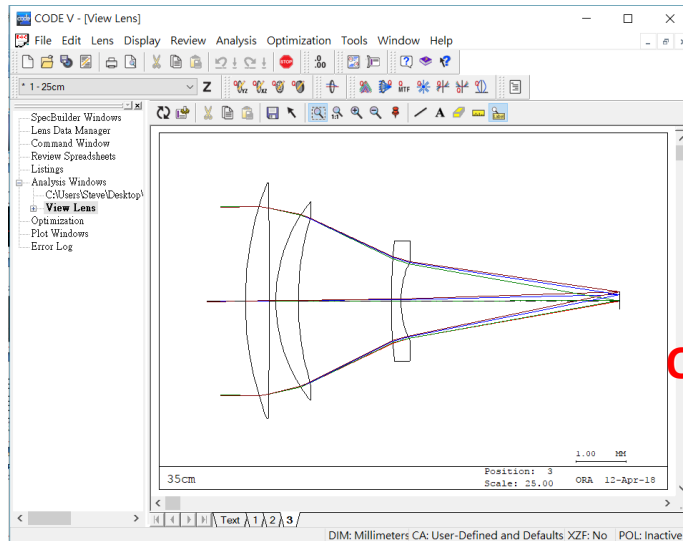

**Optimization**

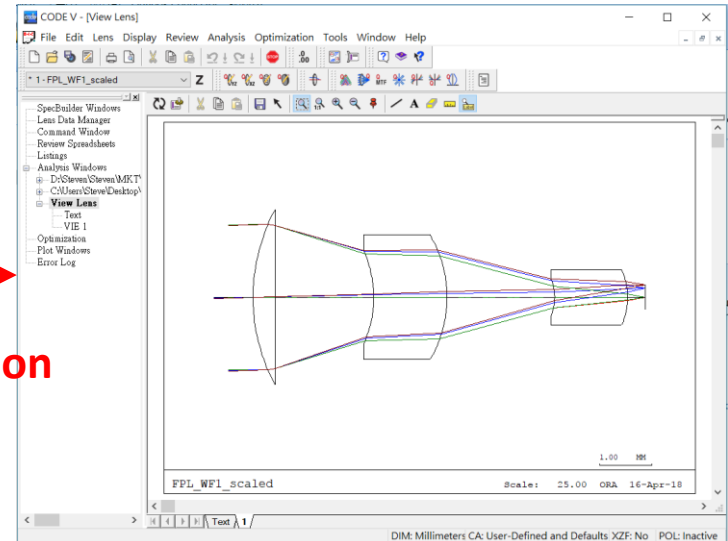

# Optical System Optimization

- In the optimization, several important variables:
  - Numbers of VCSELs in a single source array
  - Aperture of lens system
  - Size/length of projector system
  - Distance between lens and targeted plane

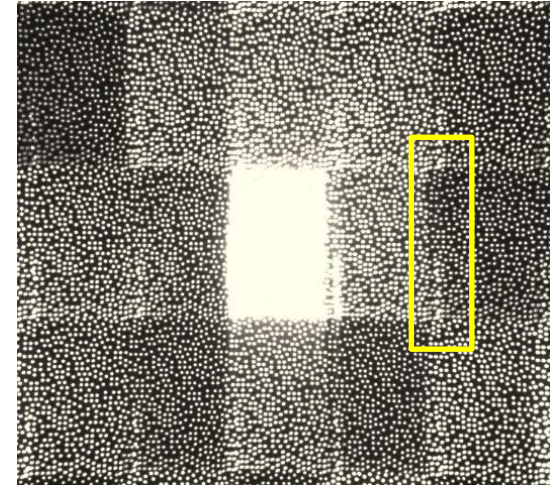

Previous Design without including the grating

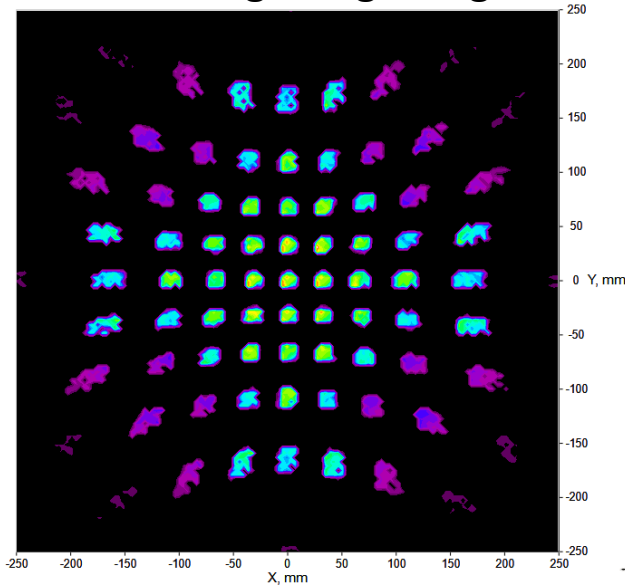

Optimized Design with including the grating

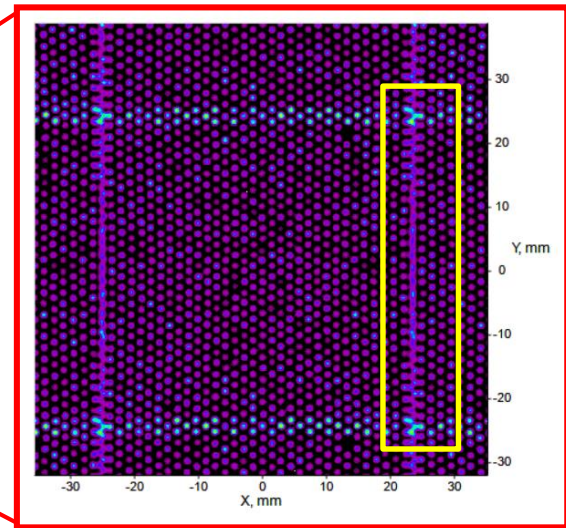
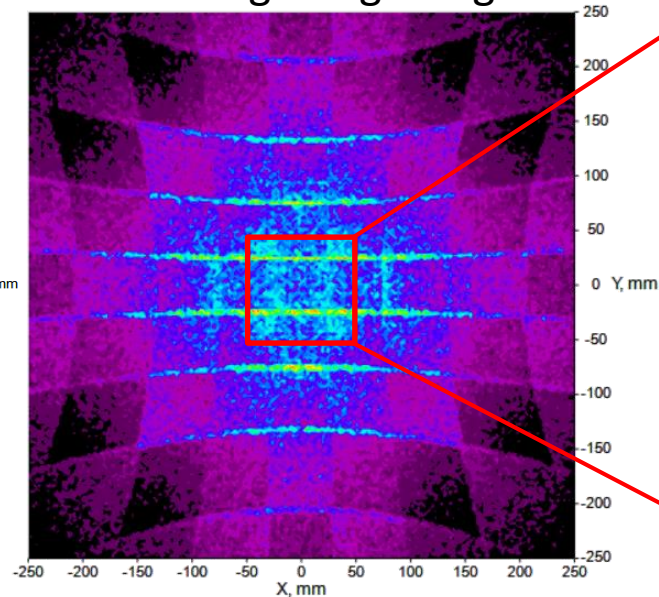



# Performance of Dot Projector

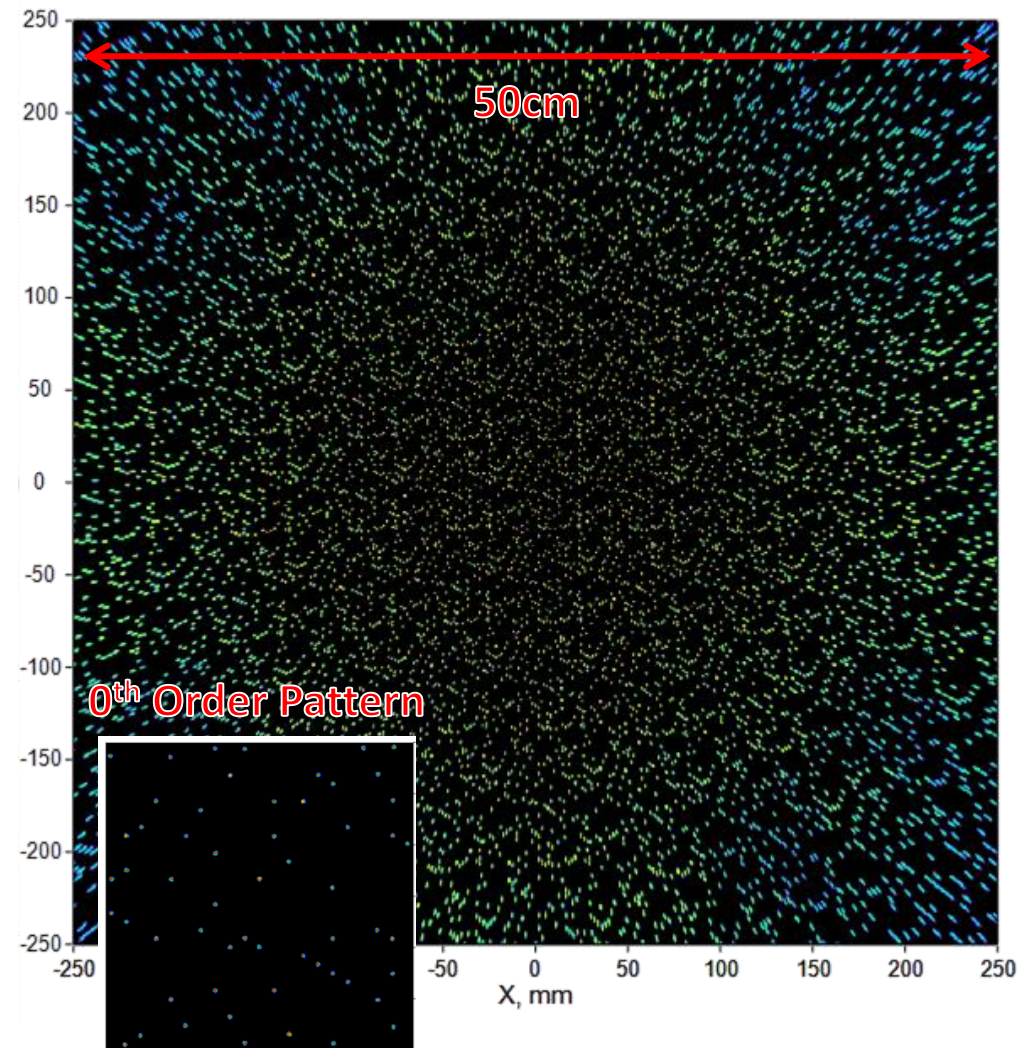

- By turning on a set of VCSELs in source array, the emitted pattern can be precisely predicted in LightTools
  - Several emitting patterns can be simulated
- Furthermore, users are able to build the objects which are going to be detected in LightTools, and collect the reflected and distorted signals by setting a receiver in a proper position
  - The reflected patterns are able to be predicted
  - Depth sensing algorithm can be calibrated by simulation

# Possible Issues of Dot Projector

- Stray light can arise from reflection or scattering off of optical/non-optical path surfaces or simply passing through surfaces which are not part of the designed optical path
  - Stray lights can be analyzed by “Ray Path” tool in LightTools
  - Possible origin of ghost images:
    - Reflection from DOEs (10%~20%)
    - Reflection from surface of lens/mirrors system
    - Reflection from mechanicals, like mount surfaces

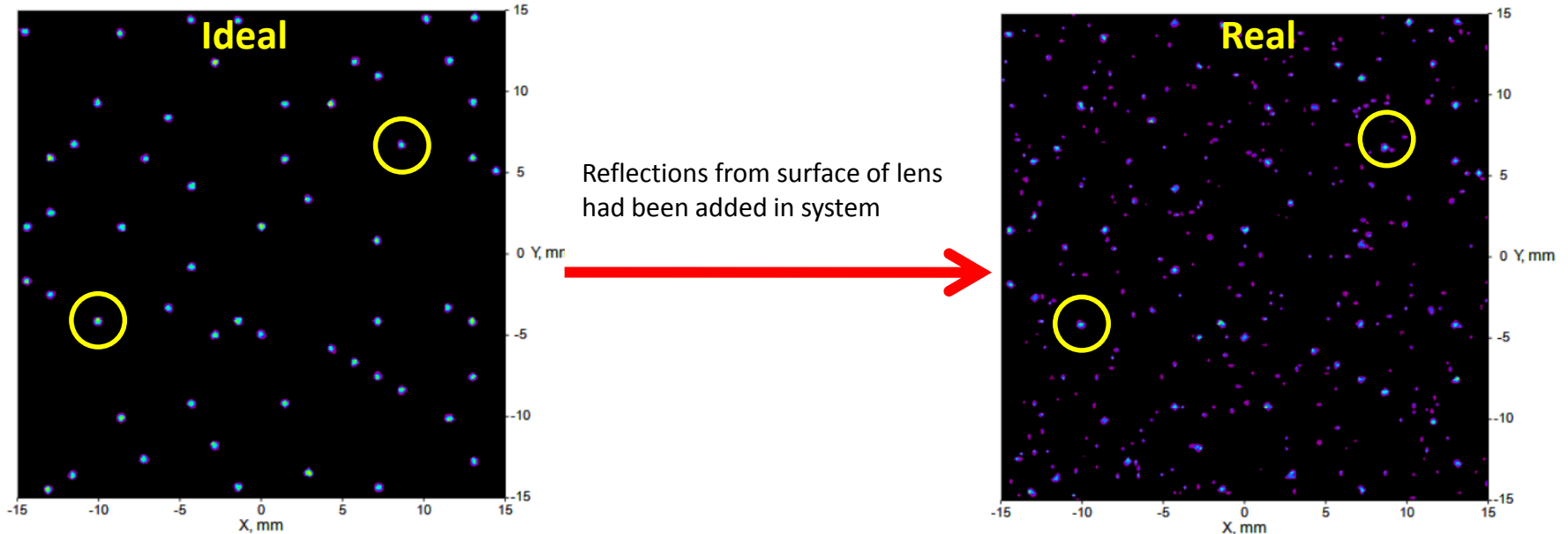

# Conclusion

- In this presentation, a possible solution to 3D depth sensing is demonstrated
  - More than 30K dots are generated
- Optical Dammann grating is built in RSoft CAD with all the details, including width, height, refractive index and period
- Diffraction properties are rigorously calculated by RSoft DiffractMOD using the RCWA algorithm, instead of solving mathematical formula of grating functions
- An optimization is performed, improving the performance of transmitted diffractions
- By integrated the BSDF file generated by RSoft BSDF Utility, diffraction properties can be visually simulated in LightTools along with lens and mechanical systems, demonstrating a comprehensive platform for optical simulation and optimization